

Measuring tree height for tropical forest trees A field manual for the CTFS sites

February 22nd 2005

Jerome Chave

chave@cict.fr

Lab. Evolution et Diversité Biologique
Université Paul Sabatier
31000 Toulouse, France

1. Introduction

Tree height is a fundamental geometrical variable for trees. Unfortunately, most measures are based on visual inspection, and they are almost always considerably biased, as it is difficult to assess the size of vertical objects 10-40 m in height. One no-biased height estimate makes use of automated distance measurement tools, as reported here.

2. Tree height measurement

Tree height will be measured using a combination of a laser rangefinder and a clinometer. The supplied laser rangefinder (Nikon Laser600, figure 1) takes measurements in yards or in meters, from 10 m to about 100 m, by increments of 0.5 m. (Note 1 yard = 0.9144 m). It is water-resistant, but not water-proof, so don't use it in the rain (you won't see tree tops anyway). The Nikon Laser600 come with one CR2 Lithium battery. Over 6,000 measurements can be achieved with just one battery. Do not throw it away when used. Store the equipment in a dry place overnight and when not used (in silicagel). Please read the notice carefully. The small button, when used together with the large button allows to convert from yard to meters. **ALWAYS MAKE MEASUREMENTS IN METERS!!** If you really can't figure out how to do it, be very clear that the measurement has been taken in yards on the field spreadsheet.



Figure 1. Left: Laser rangefinder. Right: height meter.

The second piece of equipment is an optical height meter. It includes a clear notice. From distances of 15 m or 20 m, read off the instrument the height from the horizon to the tree base, then from the horizon to the tree top.

Two strategies can be followed for measuring tree heights.

- (1) recommended option. Find a spot where you have a clear view of the tree stem at around 15 m (for understory and midstory trees), and 20 m (for canopy trees). Measure the precise horizontal distance from you to the stem using the rangefinder, L . Choose one scale in the height meter. Let us first assume that you will use the left scale (exact for a distance of 20 m). Estimate the position of the tree top, take a sighting of it through the height meter, and

read the measure $H1'$ on the left scale. Then, take a sighting of the tree base, and read the measure $H2'$ on the left scale. The height measurement is

$$H = (H1' + H2') * L / 20$$

where all distance are expressed in meters. If you choose to use the central scale, then the following formula should be used:

$$H = (H1' + H2') * L / 15$$

The rightmost scale of the height meter just provides the slope of the angle (in %). You don't need to report it. These formulas above are useful in rainforests, where it is sometimes difficult to find the right measurement spot exactly at 15 or at 20 m. Here the rangefinder is only used to find L .

This technique should work well for most understory and mid-canopy trees. It could even work very well for canopy trees in newly formed gaps.

- (2) For a number of canopy trees, however, tree height measurement is difficult because it is hard to see the upper crown. Field workers may then want to use directly the rangefinder from nearby the tree and shoot to laser beam to the upper branches or to the upper leaves. This would be a safe test to cross-check some of the measurements taken with method (1). However only trees > 10 m in height can be measured this way. Also, you should shoot at approximately 90° to avoid overestimating the tree height (note also that you should add the height from your height to the ground, usually 1,60 m). The total height is simply $H1 + H2$.

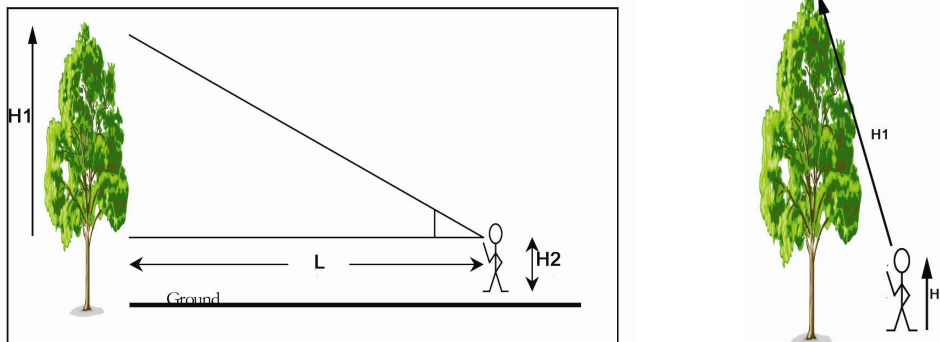

Figure 2. Left: Method 1 (recommended). Right: Method 2.

You should measure the tree heights within the Forest Dynamics Plot, to avoid the extra trouble of identifying trees. On the field spreadsheet, please record:

- (a) tree tag number
- (b) Method of measurement (1 or 2)
- (c) exact distance from the tree L **in meters** (distances of 10 m or less should be reserved for small trees, distance of 30 m or more, to tall emergents).
- (d) Exact height $H1'$ read off the height meter (for method 1) or $H1$ read off the laser range finder (for method 2)
- (e) Either exact measurement of $H2'$ for method 1 if the terrain is not flat, or no measurement at all (meaning default height).

Do not forget to record the name of the field worker and its height on the spreadsheet, as it is useful in the subsequent calculations.